

- 1
- 2
- 3
- 4
- 5
- 6
- 7
- 8
- 9
- 10
- 11
- 12
- 13
- 14
- 15
- 16
- 17
- 18
- 19

### ASSEMBLY ENDS

Glass-fibre reinforced polyamide based (PA) technopolymer, black colour.

### SUPPORT

Aluminium in natural colour.

### GRADUATED CONTRAST SCREEN

White lacquered aluminium. It can be taken out before assembly to allow the insertion of level lines or words.

### BRACKET WITH MALE CONNECTOR

Perfectly watertight, with MAX temperature sensor (80°C) and/or temperature probe.

- DIN 43650 C connector in glass-fibre reinforced polyamide based (PA) technopolymer, black colour.

- 4-pole M12x1 connector, with threading in glass-fibre reinforced polyamide based (PA) technopolymer certified self-extinguishing UL-94-V0, black colour, matte finish.

For a correct assembly see Warnings (on page 1227).

### FEMALE CONNECTOR (DIN 43650 C)

With built-in cable gland and contact holder. Front or axial output (high or low) ensuring protection against water sprays (protection class IP 65 according to table EN 60529 on page A-19).

### STANDARD EXECUTIONS

See configuration table.

### TECHNICAL DATA

In laboratory tests carried out for a relatively limited time with the following liquids at a temperature of 23° C: mineral oil type CB68 (according to ISO 3498) for HCK, mineral oil type CB68 (according to ISO 3498) water or water/glycol-based solutions ( 50%) for HCK-GL, the resistance values were much higher than 35 bar.

For use with other fluids and under different pressure and temperature conditions, please contact ELESA Technical Department.

In any case we suggest to verify the suitability of the product under the actual working conditions.

### SPECIAL EXECUTIONS ON REQUEST

- Column level window in transparent methylacrylate (PMMA) for max 70°C use.

- Indicators with level visibility (quota) up to 1429 mm and fixing holes with centre distance (quota f) up to 1500 mm.

- Packing rings in special material depending on the customer's needs.

- Special screw with nickel-plated brass tap to be fitted to the lower assembly end for any maintenance operation requiring the indicator exclusion.

### ACCESSORIES ON REQUEST

FC-M12x1: extensions with 4 pole M12 female axial connector.

### FEMALE CONNECTOR ASSEMBLY INSTRUCTIONS

1. Remove the connector from the indicator by unscrewing the set screw placed on the connector, take the contact holders out and loosen the cable gland.
2. a) HCK-ST: insert the cable into the connector (standard connector) and connect the wires to terminals 3 and ground (4) for the operation of the MAX temperature sensor. b) HCK-STL: insert the cable into the connector (standard connector) and connect the wires to terminals 3 and ground (4) for the operation of the temperature probe
3. Assemble by pressing the contact holder into the connector in the required position.
4. Screw the connectors to the indicator and then tighten the cable glands.



ELESA Original design

### FEATURES AND APPLICATIONS

The HCK-S level indicators with lateral connector output allows the level of intervention of the sensor to be minimised.

In case of use of an extension with angled connector, the direction of the cable output is shown in Fig.1.

Fig.1

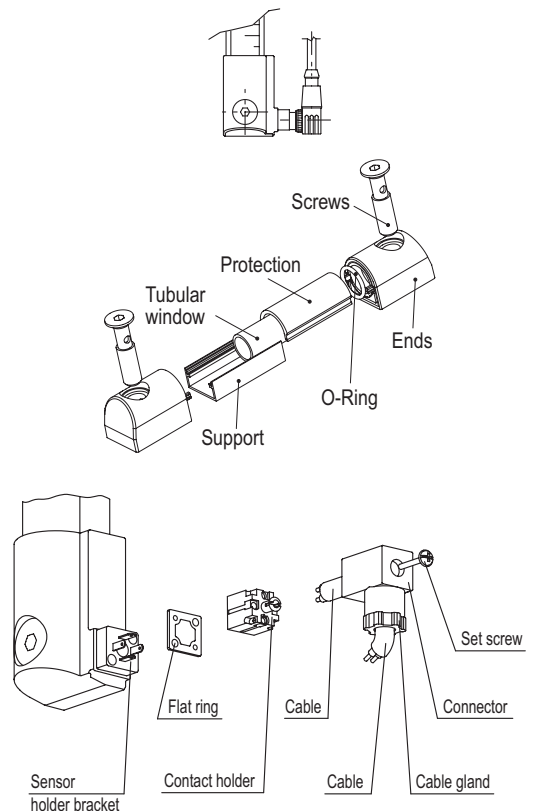

**FUNCTIONING OF THE MAX TEMPERATURE SENSOR**

- NO: the electrical contact closes when the pre-set temperature is reached at 80°C.
- NC: the electrical contact opens when the pre-set temperature at 80°C is reached.

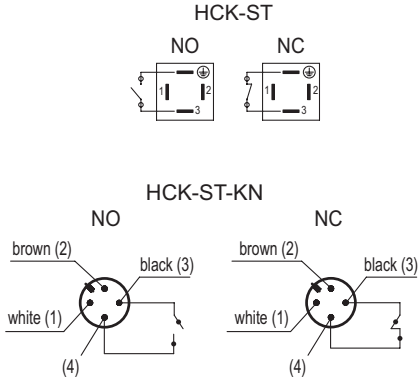

Electrical features	MAX temperature sensor
Power supply	AC/DC
Electric contacts	NO normally open
	NC normally closed
Voltage / Maximum current	250 Vac - 2 A
	115 Vac - 3 A
	24 Vdc - 3 A
	12 Vdc - 4 A
	(resistive loads) DIN 43650 C
	30 Vac, 30 Vdc
	KN
Voltage range (Type KN)	<30 Vac, <30 Vdc
Minimum current	50 mA
Cable gland	Pg 7 (for cables in sheath with Ø 6 or 7 mm)
Conductors cross-section	Max. 1.5 mm <sup>2</sup>

**FUNCTIONING OF THE TEMPERATURE ELECTRICAL PROBE (STL)**

The working principle of the temperature probe is to measure the variation of resistance of a platinum element: 100 ohm = 0°C, 138.4 ohm = 100°C.

The function between temperature (T) and resistance (R) is approximately linear over a small temperature range: for example, if you assume that it is linear over the 0° to 100°C range, the error at 50°C is 0.4°C.

For precision measurement, it is necessary to linearise the resistance to give an accurate temperature. The most recent definition of the function between resistance and temperature is International Temperature Standard 90 (ITS-90). The function between resistance and temperature, obtained in laboratory tests, measuring directly the resistance value on the contacts is shown in the graph. We suggest, anyway, to set the system in order to compensate both heat dissipation and cable resistance.

The temperature variation of 1°C causes a 0.384 ohm variation in the probe resistance. Therefore, even a small error in the resistance measurement (for example, if the resistance of the cables connecting to the probe were not considered) translates into a significant error in the temperature measurement.

Because of the low signal levels, it is important to keep any cables away from electric cables, motors, switchgear and other devices that may emit magnetic or electrical noise. Using screened cable, with the screen grounded at one end, may help to reduce interference.

Furthermore, if long connection cables are used, make sure that the signal measurement and reception device is designed to compensate for the resistance of the cables themselves.

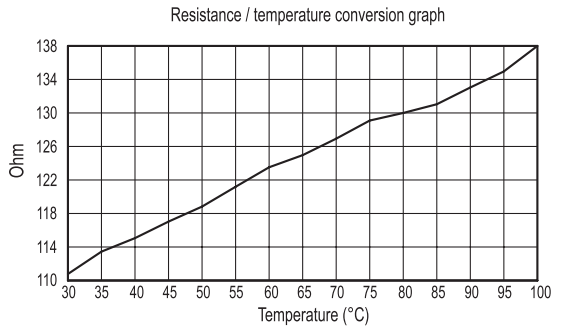

**HCK-STL-KN**

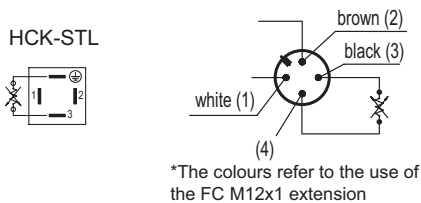

Electrical features	Temperature probe
Power supply	AC/DC
Maximum current	1mA
Cable gland	Pg 7 (for cables in sheath with Ø 6 or 7 mm)
Conductors cross-section	Max. 1.5 mm <sup>2</sup>
Do not mount this indicator in proximity to magnetic fields.	

TABLE FOR STANDARD EXECUTIONS SET-UP

	<b>HCK.</b>	-	<b>127</b>	-	<b>ZN</b>	-	<b>M12</b>	-	<b>NBR</b>	-	<b>PC</b>	-	<b>P</b>	-	<b>80-NO</b>	-	<b>KN</b>
			①		②				③		④		⑤		⑥		⑦

① Centre distance (f)	127	127 mm
	176	176 mm
	254	254 mm
	381	381 mm
	508	508 mm

② Screws, nuts and washers	<b>ZN</b>	Zinc-plated steel.
	<b>SST</b>	Steel screws, nuts and washers. AISI 304 stainless steel.
	<b>A4</b>	AISI 316 stainless steel.

③ Packing rings	<b>NBR</b>	O-Ring in NBR synthetic rubber for use with a maximum continuous operating temperature of 100°C.
	<b>FKM</b>	O-Ring in VITON® FKM synthetic rubber for use with a maximum continuous operating temperature of 130°C.

④ Tubular bubble level	<b>PC</b>	Transparent polycarbonate tube for use with oil.
	<b>GL</b>	Transparent borosilicate glass tube for use with oil, water, or water/glycol solutions (50%).

⑤ Transparent front protection	<b>P</b>	Polycarbonate (PC) plate. Removable for cleaning.
	<b>NP</b>	Without protection (for execution PC in paragraph 4).

  

⑥ Temperature Sensor / Probe	<b>80-NO *</b>	MAX temperature electrical sensor (80°C) with normally open electrical contacts. (ST version)
	<b>80-NC **</b>	MAX temperature electrical sensor (80°C) with normally closed electrical contacts. (ST version)
	<b>STL ***</b>	PT 100 temperature electrical probe.

⑦ Connector		DIN 43650 C, adjustable front or side output.
	<b>KN</b>	4-pole male M12x1

VITON® Registered trademark by DuPont Dow Elastomers.

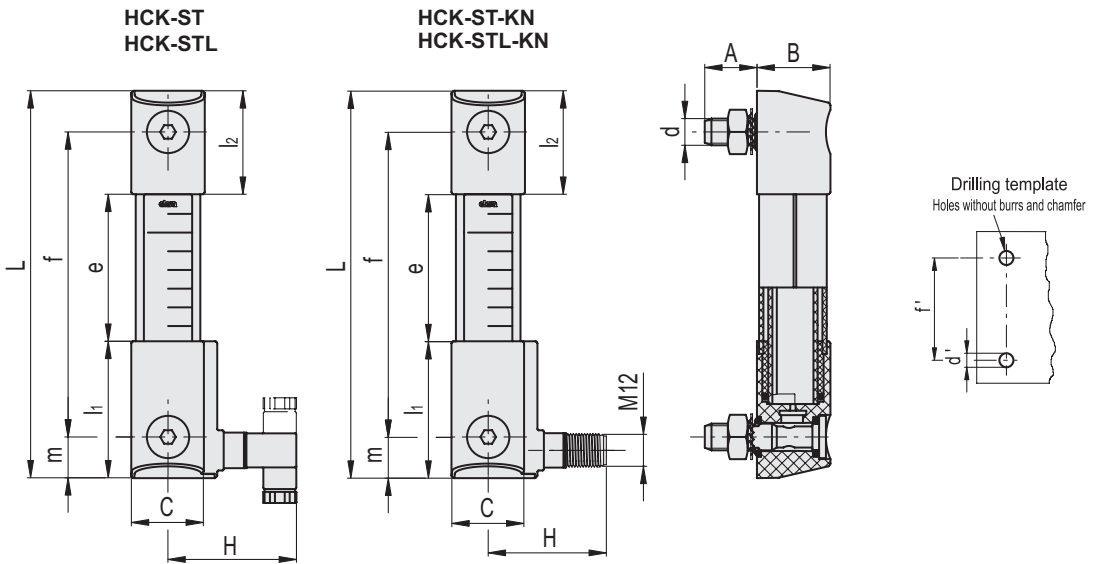

HCK-ST - HCK-STL														
f	d	A	B	C	H	L	e	l1	l2	m	d'-0.2	f±0.2	C# [Nm]	⚖
127	M12	20	33	33	59	164	56	61.5	46.5	18.5	12.5	127	12	228
176	M12	20	33	33	59	213	105	61.5	46.5	18.5	12.5	176	12	258
254	M12	20	33	33	59	291	183	61.5	46.5	18.5	12.5	254	12	305
381	M12	20	33	33	59	418	310	61.5	46.5	18.5	12.5	381	12	384
508	M12	20	33	33	59	545	437	61.5	46.5	18.5	12.5	508	12	462

HCK-ST-KN - HCK-STL-KN														
f	d	A	B	C	H	L	e	l1	l2	m	d'-0.2	f±0.2	C# [Nm]	⚖
127	M12	20	33	33	47	164	56	61.5	46.5	18.5	12.5	127	12	228
176	M12	20	33	33	47	213	105	61.5	46.5	18.5	12.5	176	12	258
254	M12	20	33	33	47	291	183	61.5	46.5	18.5	12.5	254	12	305
381	M12	20	33	33	47	418	310	61.5	46.5	18.5	12.5	381	12	384
508	M12	20	33	33	47	545	437	61.5	46.5	18.5	12.5	508	12	462

Accessories for hydraulic systems