

**MATERIAL**

Shaft locking base in polyamide based (PA) SUPER-technopolymer, black colour, matte finish.  
 Hexagon head screws in AISI 316 stainless steel.  
 Adjustable handle ERW. glass-fibre reinforced polyamide based (PA) technopolymer, grey-black colour, matte finish, with AISI 304 stainless steel boss, threaded blind hole.

**FEATURES AND APPLICATIONS**

BSA-T51 locking bases allow an easy and quick locking of the spindles after their positioning. They are equipped with a  $\varnothing 6.1$  mm hole to fit the referring pin of the indicator. They can be assembled with the handle either on the right or on the left and can be fitted to the machine by means of two M4 cylindrical-head screws (not included in the supply). Thanks to the use of stainless steel and completely technopolymer parts, it can be subjected to frequent washing and used in any situation or environment where particular attention to cleanliness and hygiene is required, such as for example food packaging or bottling machines. Furthermore, since there are no surface treatments that can deteriorate over time (for example varnishing), the characteristics of the product remain unchanged during its use.

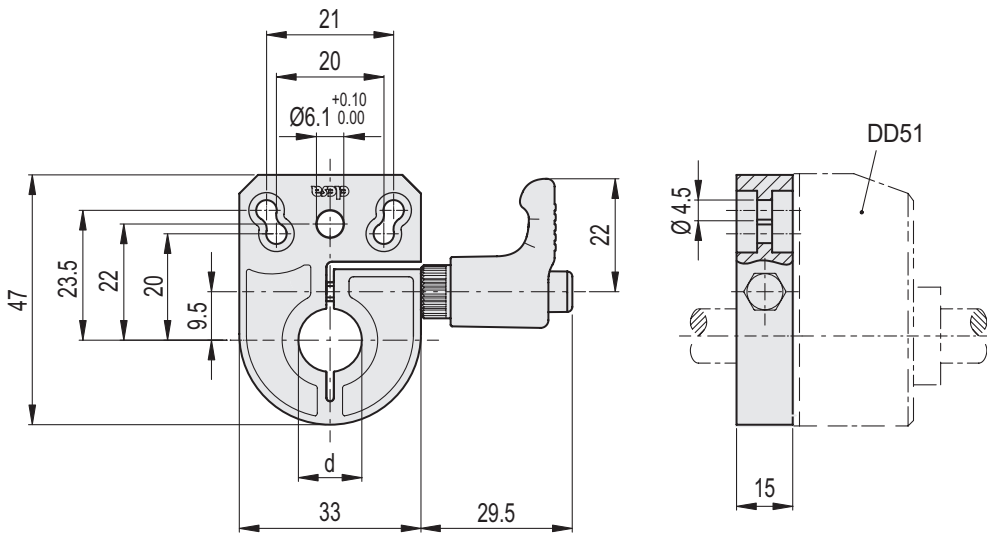

Code	Description	d	⚖
CE.95931	BSA-T51-6-SST	6	36
CE.95932	BSA-T51-8-SST	8	35
CE.95933	BSA-T51-10-SST	10	34
CE.95934	BSA-T51-12-SST	12	33
CE.95935	BSA-T51-14-SST	14	32