

Justerbara handtag med ny fästskruv med torx profil för att passa Torx®-verktyg:

Nuvarande fästskruv med insexurtag

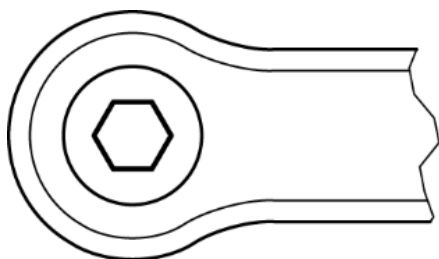

Ny fästskruv med torx profil

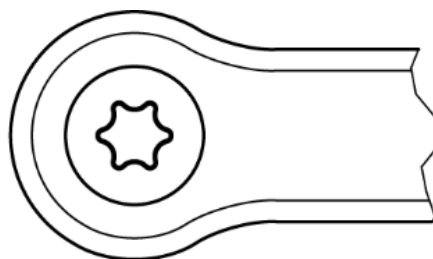

Bästa Elesa Partners,
Vi informerar er om att, på grund av ett förbättringsprojekt, kommer de befintliga justerbara handtagen [ERM.](#), [ERZ.](#), [GN 300](#), [GN 300.1](#), [GN 300.4](#), [GN 300.5](#), [GN 302](#) och [GN 306](#) att finnas tillgänglig i versionen med insexurtag så länge lagren varar. Dessa kommer sedan att ersättas med justerbara handtag som har en torx profil för att passa Torx®-verktyg (registrerat varumärke för TEXTRON INC.).



GN 300
GN 300.1
GN 300.5

GN 300.4



GN 302

ERM.



ERZ.

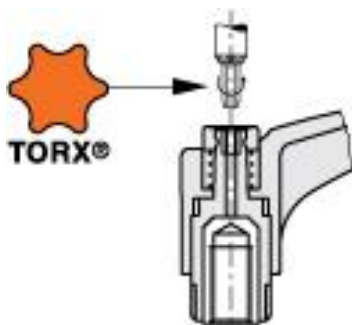

GN 306



Se även de uppdaterade databladen för de nämnda produkterna på elesa.com.
Tack för er uppmärksamhet. Vi står till ert förfogande för ytterligare information.

HANDTAG

Pressgjuten zinklegering med epoxybeläggning, RAL 9005 svart färg, matt yta.

STANDARDUTFÖRANDE

Spännelement och fästskruv med sexkantsskruv i svartoxiderat stålkruv. Returfjäder i stål.

- **GN 306-MS**: mässings spets.
- **GN 306-KU**: spets i acetalplast baserad (POM) teknopolymer, naturlig färg.
- **GN 306-DZ**: spets med härdad oval ände.
- **GN 306-ZK**: spets med sfärisk ände.
- **GN 306-KD**: spets med sfärisk ände och tryckdyna (medföljer ej monterad) gjord av acetalbaserad (POM) teknopolymer, svart färg, matt yta.

KÄNNETECKEN OCH ANVÄNDNING

Särskilt lämplig när spakens vridningsvinkel är begränsad på grund av bristande utrymme.

Spets gjord av mässing (GN 306-MS) eller acetalbaserad teknopolymer (GN 306-KU) för att undvika skador på kontaktytan.

Spets med oval ände (GN 306-DZ) för applikationer som kräver en kontaktpunkt.

Sfärisk ände med tryckdyna gjord av teknopolymer (GN 306-KD) användbar vid oregelbundna eller icke-parallella ytor för att utföra fastspänning utan att överföra rotationen på fastspänningsyta.

SPECIALUTFÖRANDE PÅ FÖRFRÅGAN

- Handtag i olika färger.
- Klämelement i rostfritt stål.
- Rakt handtag liknande GN 302.

BRUKSANVISNING

För fastspänning, lyft spaken för att frigöra kuggkransen och föra den tillbaka till utgångsläget. Genom att släppa spaken, kopplar returfjäders automatiskt in kuggkransen igen. Om spaken inte kan göra en 360° rotation kan spaken lätt skruvas fast med hjälp av sexkantsskruven (efter att ha frikopplad spaken).

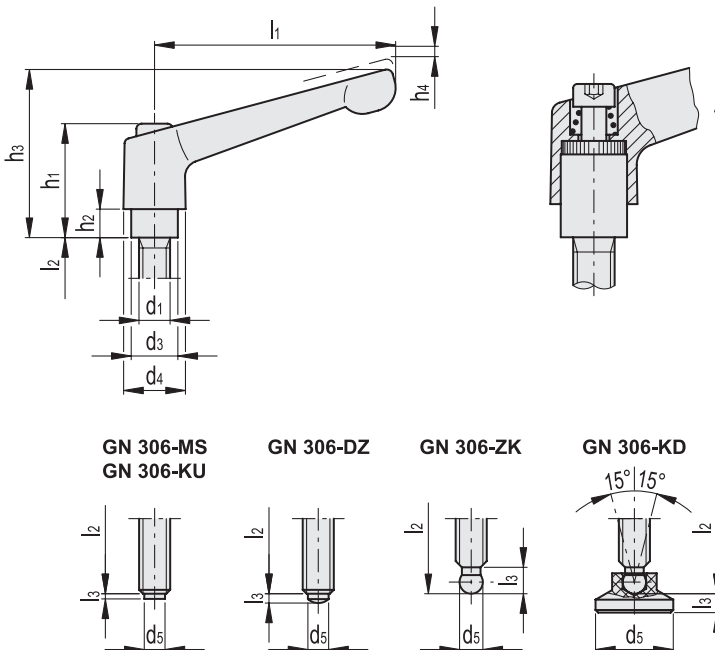

1



2



3



4



5



6



7



8



9



10



11



12



13



14



15



RH





1



2



3



4



5



6



7



8



9



10



11



12



13



14



15



RH



Låsspakar

10

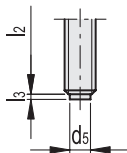
GN 306-MS
GN 306-KU

GN 306-MS

Kod	Benämning	l1	d1	d3	d4	d5	h1	h2	h3	h4	l2	l3
GN.51207	GN 306-30-M6-16-MS-SW	30	M6	10	13	4	24.5	4	31	3.5	16	1
GN.51217	GN 306-30-M6-20-MS-SW	30	M6	10	13	4	24.5	4	31	3.5	20	1
GN.51227	GN 306-30-M6-25-MS-SW	30	M6	10	13	4	24.5	4	31	3.5	25	1
GN.51237	GN 306-30-M6-32-MS-SW	30	M6	10	13	4	24.5	4	31	3.5	32	1
GN.51247	GN 306-30-M6-40-MS-SW	30	M6	10	13	4	24.5	4	31	3.5	40	1
GN.51257	GN 306-30-M6-50-MS-SW	30	M6	10	13	4	24.5	4	31	3.5	50	1
GN.51407	GN 306-45-M6-16-MS-SW	45	M6	10	13	4	24.5	4	35	3.5	16	1
GN.51417	GN 306-45-M6-20-MS-SW	45	M6	10	13	4	24.5	4	35	3.5	20	1
GN.51427	GN 306-45-M6-25-MS-SW	45	M6	10	13	4	24.5	4	35	3.5	25	1
GN.51437	GN 306-45-M6-32-MS-SW	45	M6	10	13	4	24.5	4	35	3.5	32	1
GN.51447	GN 306-45-M6-40-MS-SW	45	M6	10	13	4	24.5	4	35	3.5	40	1
GN.51457	GN 306-45-M6-50-MS-SW	45	M6	10	13	4	24.5	4	35	3.5	50	1
GN.51607	GN 306-63-M8-20-MS-SW	63	M8	13.5	17.5	6	31	6.5	45	4	20	1.5
GN.51617	GN 306-63-M8-25-MS-SW	63	M8	13.5	17.5	6	31	6.5	45	4	25	1.5
GN.51627	GN 306-63-M8-32-MS-SW	63	M8	13.5	17.5	6	31	6.5	45	4	32	1.5
GN.51637	GN 306-63-M8-40-MS-SW	63	M8	13.5	17.5	6	31	6.5	45	4	40	1.5
GN.51647	GN 306-63-M8-50-MS-SW	63	M8	13.5	17.5	6	31	6.5	45	4	50	1.5
GN.51657	GN 306-63-M8-63-MS-SW	63	M8	13.5	17.5	6	31	6.5	45	4	63	1.5
GN.51667	GN 306-63-M10-20-MS-SW	63	M10	13.5	17.5	8	31	6.5	45	4	20	2
GN.51677	GN 306-63-M10-25-MS-SW	63	M10	13.5	17.5	8	31	6.5	45	4	25	2
GN.51687	GN 306-63-M10-32-MS-SW	63	M10	13.5	17.5	8	31	6.5	45	4	32	2
GN.51697	GN 306-63-M10-40-MS-SW	63	M10	13.5	17.5	8	31	6.5	45	4	40	2
GN.51707	GN 306-63-M10-50-MS-SW	63	M10	13.5	17.5	8	31	6.5	45	4	50	2
GN.51717	GN 306-63-M10-63-MS-SW	63	M10	13.5	17.5	8	31	6.5	45	4	63	2

GN 306-KU

Kod	Benämning	l1	d1	d3	d4	d5	h1	h2	h3	h4	l2	l3
GN.51205	GN 306-30-M6-16-KU-SW	30	M6	10	13	3.5	24.5	4	31	3.5	16	1.3
GN.51215	GN 306-30-M6-20-KU-SW	30	M6	10	13	3.5	24.5	4	31	3.5	20	1.3
GN.51225	GN 306-30-M6-25-KU-SW	30	M6	10	13	3.5	24.5	4	31	3.5	25	1.3
GN.51235	GN 306-30-M6-32-KU-SW	30	M6	10	13	3.5	24.5	4	31	3.5	32	1.3
GN.51245	GN 306-30-M6-40-KU-SW	30	M6	10	13	3.5	24.5	4	31	3.5	40	1.3
GN.51255	GN 306-30-M6-50-KU-SW	30	M6	10	13	3.5	24.5	4	31	3.5	50	1.3
GN.51405	GN 306-45-M6-16-KU-SW	45	M6	10	13	3.5	24.5	4	35	3.5	16	1.3
GN.51415	GN 306-45-M6-20-KU-SW	45	M6	10	13	3.5	24.5	4	35	3.5	20	1.3
GN.51425	GN 306-45-M6-25-KU-SW	45	M6	10	13	3.5	24.5	4	35	3.5	25	1.3
GN.51435	GN 306-45-M6-32-KU-SW	45	M6	10	13	3.5	24.5	4	35	3.5	32	1.3
GN.51445	GN 306-45-M6-40-KU-SW	45	M6	10	13	3.5	24.5	4	35	3.5	40	1.3
GN.51455	GN 306-45-M6-50-KU-SW	45	M6	10	13	3.5	24.5	4	35	3.5	50	1.3
GN.51605	GN 306-63-M8-20-KU-SW	63	M8	13.5	17.5	5	31	6.5	45	4	20	1.6
GN.51615	GN 306-63-M8-25-KU-SW	63	M8	13.5	17.5	5	31	6.5	45	4	25	1.6
GN.51625	GN 306-63-M8-32-KU-SW	63	M8	13.5	17.5	5	31	6.5	45	4	32	1.6
GN.51635	GN 306-63-M8-40-KU-SW	63	M8	13.5	17.5	5	31	6.5	45	4	40	1.6
GN.51645	GN 306-63-M8-50-KU-SW	63	M8	13.5	17.5	5	31	6.5	45	4	50	1.6
GN.51655	GN 306-63-M8-63-KU-SW	63	M8	13.5	17.5	5	31	6.5	45	4	63	1.6
GN.51665	GN 306-63-M10-20-KU-SW	63	M10	13.5	17.5	6.5	31	6.5	45	4	20	1.9
GN.51675	GN 306-63-M10-25-KU-SW	63	M10	13.5	17.5	6.5	31	6.5	45	4	25	1.9
GN.51685	GN 306-63-M10-32-KU-SW	63	M10	13.5	17.5	6.5	31	6.5	45	4	32	1.9
GN.51695	GN 306-63-M10-40-KU-SW	63	M10	13.5	17.5	6.5	31	6.5	45	4	40	1.9
GN.51705	GN 306-63-M10-50-KU-SW	63	M10	13.5	17.5	6.5	31	6.5	45	4	50	1.9
GN.51715	GN 306-63-M10-63-KU-SW	63	M10	13.5	17.5	6.5	31	6.5	45	4	63	1.9



GN 306-DZ

Kod	Benämning	l1	d1	d3	d4	d5	h1	h2	h3	h4	l2	l3
GN.51201	GN 306-30-M6-16-DZ-SW	30	M6	10	13	4	24.5	4	31	3.5	16	1.8
GN.51211	GN 306-30-M6-20-DZ-SW	30	M6	10	13	4	24.5	4	31	3.5	20	1.8
GN.51221	GN 306-30-M6-25-DZ-SW	30	M6	10	13	4	24.5	4	31	3.5	25	1.8
GN.51231	GN 306-30-M6-32-DZ-SW	30	M6	10	13	4	24.5	4	31	3.5	32	1.8
GN.51241	GN 306-30-M6-40-DZ-SW	30	M6	10	13	4	24.5	4	31	3.5	40	1.8
GN.51251	GN 306-30-M6-50-DZ-SW	30	M6	10	13	4	24.5	4	31	3.5	50	1.8
GN.51401	GN 306-45-M6-16-DZ-SW	45	M6	10	13	4	24.5	4	35	3.5	16	1.8
GN.51411	GN 306-45-M6-20-DZ-SW	45	M6	10	13	4	24.5	4	35	3.5	20	1.8
GN.51421	GN 306-45-M6-25-DZ-SW	45	M6	10	13	4	24.5	4	35	3.5	25	1.8
GN.51431	GN 306-45-M6-32-DZ-SW	45	M6	10	13	4	24.5	4	35	3.5	32	1.8
GN.51441	GN 306-45-M6-40-DZ-SW	45	M6	10	13	4	24.5	4	35	3.5	40	1.8
GN.51451	GN 306-45-M6-50-DZ-SW	45	M6	10	13	4	24.5	4	35	3.5	50	1.8
GN.51601	GN 306-63-M8-20-DZ-SW	63	M8	13.5	17.5	6	31	6.5	45	4	20	2.5
GN.51611	GN 306-63-M8-25-DZ-SW	63	M8	13.5	17.5	6	31	6.5	45	4	25	2.5
GN.51621	GN 306-63-M8-32-DZ-SW	63	M8	13.5	17.5	6	31	6.5	45	4	32	2.5
GN.51631	GN 306-63-M8-40-DZ-SW	63	M8	13.5	17.5	6	31	6.5	45	4	40	2.5
GN.51641	GN 306-63-M8-50-DZ-SW	63	M8	13.5	17.5	6	31	6.5	45	4	50	2.5
GN.51651	GN 306-63-M8-63-DZ-SW	63	M8	13.5	17.5	6	31	6.5	45	4	63	2.5
GN.51661	GN 306-63-M10-20-DZ-SW	63	M10	13.5	17.5	8	31	6.5	45	4	20	3.5
GN.51671	GN 306-63-M10-25-DZ-SW	63	M10	13.5	17.5	8	31	6.5	45	4	25	3.5
GN.51681	GN 306-63-M10-32-DZ-SW	63	M10	13.5	17.5	8	31	6.5	45	4	32	3.5
GN.51691	GN 306-63-M10-40-DZ-SW	63	M10	13.5	17.5	8	31	6.5	45	4	40	3.5
GN.51701	GN 306-63-M10-50-DZ-SW	63	M10	13.5	17.5	8	31	6.5	45	4	50	3.5
GN.51711	GN 306-63-M10-63-DZ-SW	63	M10	13.5	17.5	8	31	6.5	45	4	63	3.5

GN 306-ZK

Kod	Benämning	l1	d1	d3	d4	d5	h1	h2	h3	h4	l2	l3
GN.51209	GN 306-30-M6-16-ZK-SW	30	M6	10	13	4.5±0.03	24.5	4	31	3.5	16	5.1
GN.51219	GN 306-30-M6-20-ZK-SW	30	M6	10	13	4.5±0.03	24.5	4	31	3.5	20	5.1
GN.51229	GN 306-30-M6-25-ZK-SW	30	M6	10	13	4.5±0.03	24.5	4	31	3.5	25	5.1
GN.51239	GN 306-30-M6-32-ZK-SW	30	M6	10	13	4.5±0.03	24.5	4	31	3.5	32	5.1
GN.51249	GN 306-30-M6-40-ZK-SW	30	M6	10	13	4.5±0.03	24.5	4	31	3.5	40	5.1
GN.51259	GN 306-30-M6-50-ZK-SW	30	M6	10	13	4.5±0.03	24.5	4	31	3.5	50	5.1
GN.51409	GN 306-45-M6-16-ZK-SW	45	M6	10	13	4.5±0.03	24.5	4	35	3.5	16	5.1
GN.51419	GN 306-45-M6-20-ZK-SW	45	M6	10	13	4.5±0.03	24.5	4	35	3.5	20	5.1
GN.51429	GN 306-45-M6-25-ZK-SW	45	M6	10	13	4.5±0.03	24.5	4	35	3.5	25	5.1
GN.51439	GN 306-45-M6-32-ZK-SW	45	M6	10	13	4.5±0.03	24.5	4	35	3.5	32	5.1
GN.51449	GN 306-45-M6-40-ZK-SW	45	M6	10	13	4.5±0.03	24.5	4	35	3.5	40	5.1
GN.51459	GN 306-45-M6-50-ZK-SW	45	M6	10	13	4.5±0.03	24.5	4	35	3.5	50	5.1
GN.51609	GN 306-63-M8-20-ZK-SW	63	M8	13.5	17.5	6.1±0.05	31	6.5	45	4	20	6.2
GN.51619	GN 306-63-M8-25-ZK-SW	63	M8	13.5	17.5	6.1±0.05	31	6.5	45	4	25	6.2
GN.51629	GN 306-63-M8-32-ZK-SW	63	M8	13.5	17.5	6.1±0.05	31	6.5	45	4	32	6.2
GN.51639	GN 306-63-M8-40-ZK-SW	63	M8	13.5	17.5	6.1±0.05	31	6.5	45	4	40	6.2
GN.51649	GN 306-63-M8-50-ZK-SW	63	M8	13.5	17.5	6.1±0.05	31	6.5	45	4	50	6.2
GN.51659	GN 306-63-M8-63-ZK-SW	63	M8	13.5	17.5	6.1±0.05	31	6.5	45	4	63	6.2
GN.51669	GN 306-63-M10-20-ZK-SW	63	M10	13.5	17.5	7.8±0.05	31	6.5	45	4	20	7.3
GN.51679	GN 306-63-M10-25-ZK-SW	63	M10	13.5	17.5	7.8±0.05	31	6.5	45	4	25	7.3
GN.51689	GN 306-63-M10-32-ZK-SW	63	M10	13.5	17.5	7.8±0.05	31	6.5	45	4	32	7.3
GN.51699	GN 306-63-M10-40-ZK-SW	63	M10	13.5	17.5	7.8±0.05	31	6.5	45	4	40	7.3
GN.51709	GN 306-63-M10-50-ZK-SW	63	M10	13.5	17.5	7.8±0.05	31	6.5	45	4	50	7.3
GN.51719	GN 306-63-M10-63-ZK-SW	63	M10	13.5	17.5	7.8±0.05	31	6.5	45	4	63	7.3





1



2



3



4



5



6



7



8



9



10



11



12



13



14



15



RH



Låsspakar

12

GN 306-KD

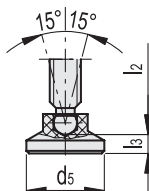

GN 306-KD

Kod	Benämning	l1	d1	d3	d4	d5	h1	h2	h3	h4	l2	l3
GN.51203	GN 306-30-M6-16-KD-SW	30	M6	10	13	15	24.5	4	31	3.5	16	3.6
GN.51213	GN 306-30-M6-20-KD-SW	30	M6	10	13	15	24.5	4	31	3.5	20	3.6
GN.51223	GN 306-30-M6-25-KD-SW	30	M6	10	13	15	24.5	4	31	3.5	25	3.6
GN.51233	GN 306-30-M6-32-KD-SW	30	M6	10	13	15	24.5	4	31	3.5	32	3.6
GN.51243	GN 306-30-M6-40-KD-SW	30	M6	10	13	15	24.5	4	31	3.5	40	3.6
GN.51253	GN 306-30-M6-50-KD-SW	30	M6	10	13	15	24.5	4	31	3.5	50	3.6
GN.51403	GN 306-45-M6-16-KD-SW	45	M6	10	13	15	24.5	4	35	3.5	16	3.6
GN.51413	GN 306-45-M6-20-KD-SW	45	M6	10	13	15	24.5	4	35	3.5	20	3.6
GN.51423	GN 306-45-M6-25-KD-SW	45	M6	10	13	15	24.5	4	35	3.5	25	3.6
GN.51433	GN 306-45-M6-32-KD-SW	45	M6	10	13	15	24.5	4	35	3.5	32	3.6
GN.51443	GN 306-45-M6-40-KD-SW	45	M6	10	13	15	24.5	4	35	3.5	40	3.6
GN.51453	GN 306-45-M6-50-KD-SW	45	M6	10	13	15	24.5	4	35	3.5	50	3.6
GN.51603	GN 306-63-M8-20-KD-SW	63	M8	13.5	17.5	18	31	6.5	45	4	20	4.2
GN.51613	GN 306-63-M8-25-KD-SW	63	M8	13.5	17.5	18	31	6.5	45	4	25	4.2
GN.51623	GN 306-63-M8-32-KD-SW	63	M8	13.5	17.5	18	31	6.5	45	4	32	4.2
GN.51633	GN 306-63-M8-40-KD-SW	63	M8	13.5	17.5	18	31	6.5	45	4	40	4.2
GN.51643	GN 306-63-M8-50-KD-SW	63	M8	13.5	17.5	18	31	6.5	45	4	50	4.2
GN.51653	GN 306-63-M8-63-KD-SW	63	M8	13.5	17.5	18	31	6.5	45	4	63	4.2
GN.51663	GN 306-63-M10-20-KD-SW	63	M10	13.5	17.5	21	31	6.5	45	4	20	4.3
GN.51673	GN 306-63-M10-25-KD-SW	63	M10	13.5	17.5	21	31	6.5	45	4	25	4.3
GN.51683	GN 306-63-M10-32-KD-SW	63	M10	13.5	17.5	21	31	6.5	45	4	32	4.3
GN.51693	GN 306-63-M10-40-KD-SW	63	M10	13.5	17.5	21	31	6.5	45	4	40	4.3
GN.51703	GN 306-63-M10-50-KD-SW	63	M10	13.5	17.5	21	31	6.5	45	4	50	4.3
GN.51713	GN 306-63-M10-63-KD-SW	63	M10	13.5	17.5	21	31	6.5	45	4	63	4.3