

# M.443 ESD

## Handle

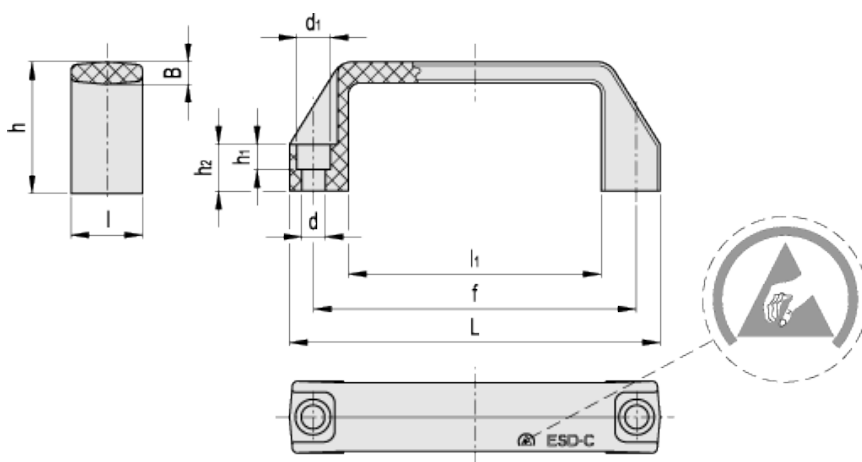

ELESA Original design



Elesa Standards		Main dimensions						Mounting holes				F <sub>1</sub>	F <sub>2</sub>	L <sub>1</sub>	L <sub>2</sub>	Weight
Code	Description	L	f	h	B	l	l <sub>1</sub>	d	d <sub>1</sub>	h <sub>1</sub>	h <sub>2</sub>	[N]	[N]	[J]	[J]	g
154601	M.443/110-CH-ESD-C	109	93.5±0.5	38	6	21	74	6.5	10.5	7	13	3500	2500	15	8	21
154611	M.443/140-8-CH-ESD-C	137	117±1	41	7	26	93	8.5	13.5	8.5	15	4500	2500	20	13	34

### Material

Glass-fibre reinforced polyamide based (PA) special conductive technopolymer. Resistant to solvents, oils, greases and other chemical agents. 10<sup>3</sup> Ω surface resistivity (ASTM D257 trial method), 10<sup>3</sup> Ωcm volume resistivity (ASTM D257 trial method).

### Colour

Black, matte finish.

### Standard execution

Pass-through holes for cylindrical head screws with hexagon socket.

### Features and applications

The special conductive technopolymer (ESD-C Electrostatic Discharge Conductive) prevents the accumulation of electrostatic charge. M.443-ESD handles are suitable for ESD PROTECTED AREA (EPA) where components which are susceptible to electrostatic discharges are to be handled with the minimum risk of damage. The indelibly printed mark (ESD-C) on the surface of the handle identifies the particular conductivity feature according to EN 100015/1 and IEC 61340-5-1.

### Technical data

Tensile stress and impact strength: F<sub>1</sub>, F<sub>2</sub>, L<sub>1</sub> and L<sub>2</sub> values reported in the table are the result of breaking tests carried out with the appropriate dynamometric equipment under the test conditions shown in the figure with ambient temperature.

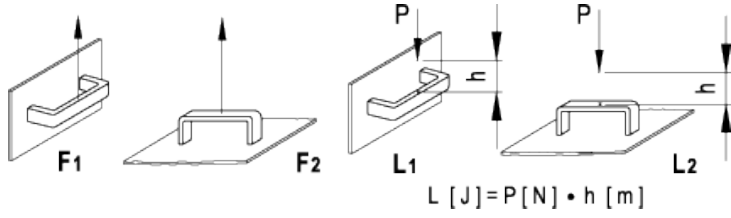

STANDAARD MACHINE ELEMENTS WORLDWIDE

ELESA models all rights reserved in accordance with the law. Always mention the source when reproducing our drawings.